

PPxx-2500FP

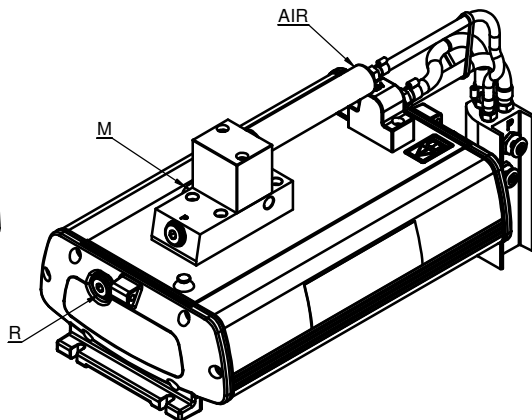

PPxx-2500RC

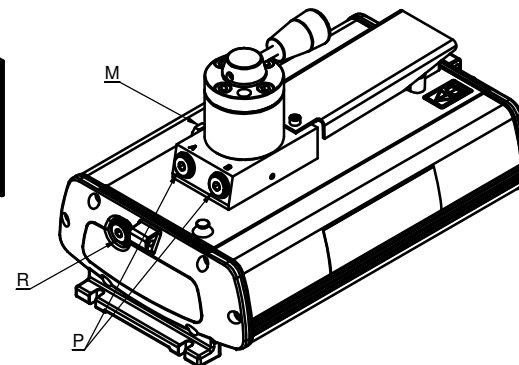

PPxx-2500MLD

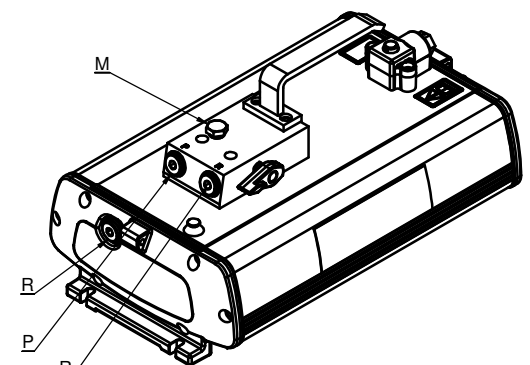

PPxx-2500MRV

Name	Working pressure MPa	Capacity cm ³ /min 1)	Air pressure MPa 2)	Eff. oil vol. cm ³	P Pressure connection	R Return conn. / oil refill	AIR Air connection	M Gauge connection	A mm	B mm	C mm	D mm	E mm	F mm	Weight kg
PP70-2500RC	70	1070-200	0,65-1,0	2500	G1/4"	G1/4"	G1/4"	G1/4" 3)	355	175	209	340	100	6,5	10,8
PP70-2500MLD	70	1150-260	0,65-1,0	2500	2x G1/4" *	G1/4"	G1/4"	G1/4" 3)	355	214	209	340	100	6,5	10,5
PP70-2500MRV	70	1150-260	0,65-1,0	2500	G1/4"	G1/4"	G1/4"	G1/4" 3)	355	171	209	340	100	6,5	9,8
PP80-2500FP	80	760-170	0,6-1,0	2500	G1/4"	G1/4"	G1/4"	---	355	187	209	340	100	6,5	10,1
PP80-2500RC	80	710-130	0,6-1,0	2500	G1/4"	G1/4"	G1/4"	G1/4" 3)	355	175	209	340	100	6,5	10,8
PP80-2500MLD	80	760-170	0,6-1,0	2500	2x G1/4" *	G1/4"	G1/4"	G1/4" 3)	355	214	209	340	100	6,5	10,5
PP80-2500MRV	80	760-170	0,6-1,0	2500	G1/4"	G1/4"	G1/4"	G1/4" 3)	355	171	209	340	100	6,5	9,8
PP100-2500FP	100	760-100	0,65-1,0	2500	G1/4"	G1/4"	G1/4"	---	355	187	209	340	100	6,5	10,8
PP100-2500RC	100	710-80	0,65-1,0	2500	G1/4"	G1/4"	G1/4"	G1/4" 3)	355	175	209	340	100	6,5	11,5
PP70-2500FP	70	1150-260	0,65-1,0	2500	G1/4"	G1/4"	G1/4"	---	355	187	209	340	100	6,5	10,1

1) @ 0,7 MPa air pressure

2) To reach the maximum working pressure

3) Connection for pressure gauge AMT801

*) 2 connections are functioning both as pressure and return connections, depending on the position of the directional valve

Material	Blank, dimension	Heat treatment	Surface treatment
Permissible deviations for dimensions without indication of tolerances Machined parts acc.SS-ISO-2768-1		Castings acc.SS-ISO-8062	Fuse welded constr. acc.SS-EN ISO 13920
Designed by CS1	Date 2012-07-02	Product	Surface roughness unless specified <input checked="" type="checkbox"/> Ra um
Prod appr. mh1 2012-11-07	Design appr. AN1 2012-11-07	Scale 1:2	Tol.system acc. ISO Replaces
REHOBOT			Replaced by
Title Dimension drawing			B-50020