

CLF110-30, CLF220-50

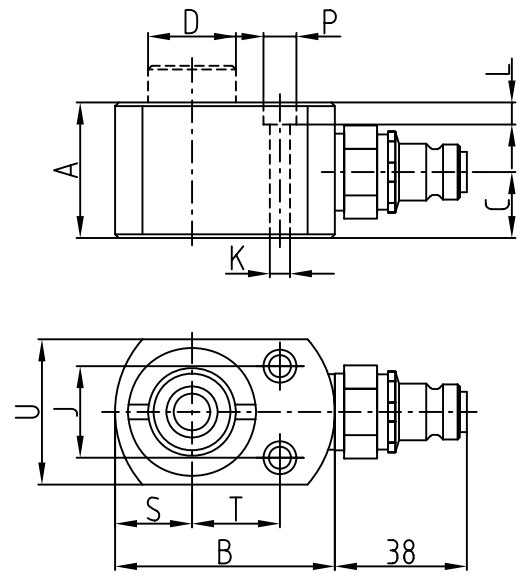

CLF50-10 - CLF450-15

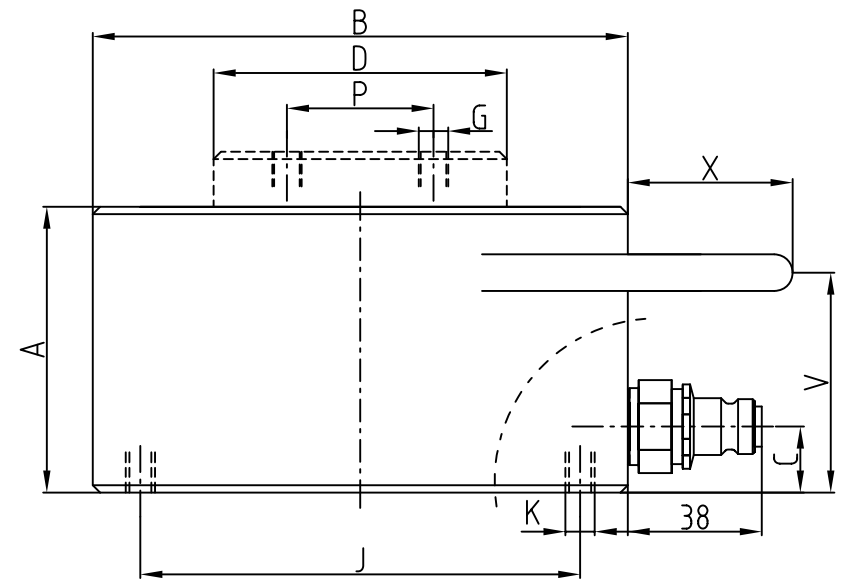

CLF450-40 - CLF2000-16

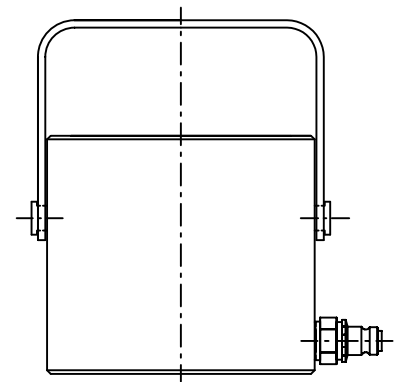

SCALE 1:2

CLF670-45, CLF1000-40



Modell	Max arbets-tryck, MPa	Kapacitet kN	Slaglängd mm	Kolvarea cm ²	Slagvolym cm ³	A mm	B Ømm	C mm	D Ømm	G mm	J mm	K Ømm	L mm	P Ømm	S mm	T mm	U mm	V mm	X mm	Y mm	Vikt kg	
CLF50-10	70	49	10	7,1	7,1	37	60	18	24	---	25	Ø5,5	6	10	20	25	40	---	---	---	0,6	
CLF110-10	70	111	10	15,9	15,9	43	80	18	35	---	40	Ø5,5	6	10	33	32	66	---	---	---	1,5	
CLF220-13	70	218	13,5	31,2	42,1	50	100	20	50	---	40	Ø5,5	6	10	44	41	86	---	---	---	2,6	
CLF450-15	70	445	15	63,6	95,4	68	134	20	60	---	67	Ø12	11	18	60	50,8	120	---	---	---	6,4	
CLF110-30	70	111	28	15,9	44,5	75	65	20	35	---	40	M6	---	---	---	---	---	---	---	---	51	1,8
CLF220-50	70	218	50	31,2	156	107	85	20	50	---	55	M6	---	---	---	---	---	---	---	---	51	3,9
CLF450-40	70	445	40	63,6	254,4	120	120	20	60	---	75	M8	---	---	---	---	---	---	---	---	---	8,8
CLF670-15	70	665	15	95	142,5	78	146	20	80	---	110	M8	---	---	---	---	60	45	---	---	---	9,2
CLF1100-15	70	1078	15	154	231	90	180	20	100	---	120	M8	---	---	---	---	60	53	---	---	---	17
CLF1500-15	70	1498	15	214	321	100	220	27	125	M8	150	M10	---	70	---	---	80	58	---	---	---	28
CLF2000-16	70	1985	16	284	454	110	250	30	140	M8	200	M10	---	70	---	---	80	61	---	---	---	40
CLF670-45 *	70	665	45	95	427,5	130	146	20	80	---	95	M10	---	---	---	---	85	---	---	---	---	14,3
CLF1100-40 *	70	1078	40	154	616	140	180	25	100	---	120	M12	---	---	---	---	95	---	---	---	---	23,7

* Levereras med bärhandtag (handtaget är löstagbart)



Material		Ansn.dimension		Värmebehandling		Ytbehandling	
Tillföra måttavvikelse där ej annat anges		Gjutna del.		Smältsvetsade konstr.		Ytjämnhet där ej annat anges	
Bearbetade del. enl.SS-ISO-2768-L		Datum 05-12-09		Produkt		Tol-system enl.ISO	
Konstr.	MN	Skala	CLF - CYLINDRAR		Ersätter		E
Prod.godl.	Konstr.godl.	Skala	Benämning		Ersatt av		
REHOBOT®		MÅTTTRITNING				B-35613	

Pos.	Ändring	Datum	Sign.
------	---------	-------	-------