

CPF 709

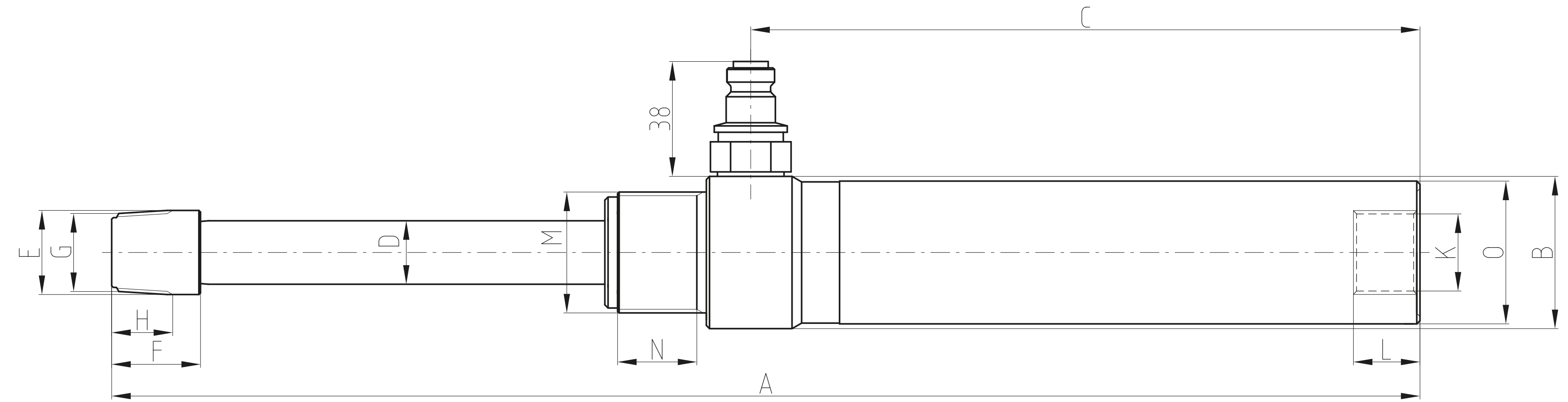

CPF 705

Modell	Max arbets-tryck, MPa	Kapacitet kN	Slaglängd mm	Kolvarea cm <sup>2</sup>	Slagvolym cm <sup>3</sup>	A mm	B Ømm	C mm	D Ømm	E Ømm	F mm	G	H mm	K	L mm	M	N mm	O mm	Vikt kg
CPF 705	70	45	125	6,5	80	412,5	48	211	20	26,5	28	3/4"-14NPT	17,5	3/4"-14NPT	20	1 1/2"-16UN	25	44,5	2,4
CPF 709	70	110	127	15,7	199	436	68	215	32	46	35	1 1/4"-11 1/2NPT	25,9	1 1/4"-11 1/2NPT	20	2 1/4"-14UN	26	70	5,9

Material		Amne, dimension		Värmebehandling		Ytbehandling	
Tillåtna måttavvikelser där ej annat anges				Gjutna det.			
Bearbetade det.		enl. SS-ISO-2768-1		Smältsvetsade konstr.		enl. SMS 723	
Konstr.		Ritad	MN	Datum	05-12-20	Produkt	
Prod. godk. ÅR		Konstr. godk.	AN	Skala	1:1	CPF - CYLINDRAR	
100531		100531				Benämning	
<b>REHOBOT</b>						MÅTTRITNING	
						Tol system enl. ISO	
						Ersätter	
						C-27418	
						Ersatt av	
						B-27418	